



PASCHIM BANGA GRAMIN BANK

Head Office: Natabar Pal Road, Chatterjee Para More, Tikiapara,, Howrah-711101.
Phone No: 033-2667-9391, Fax No: 033-2667- 9589/0051

NOTICE

Dated: 06-10-2023

Quotations are invited for furniture & fixing work, required to meet up urgent official need of Paschim Banga Gramin Bank, Head Office situated at Natabar Paul Road, Chatterjee Para More, Tikiapara, Howrah – 711101. Willing reputed vendors / suppliers are requested to submit applications/quotations at the earliest as per specifications, schedule and other terms and conditions mentioned here-in-below:

Specification of Items with quantity:

➤ **Item No. – 1.**

As detailed in Enclosure - 1.

➤ **Item No. – 2.**

As detailed in Enclosure - 2.

➤ **Item No. – 3.**

As detailed in Enclosure - 3.

Terms and Conditions:

- Intended vendor(s) will have to quote against all the above items and sum total of all the groups will be counted for declaring L1 Vendor. In all cases, Bank may allow the quotation paper at full discretion of the Bank.
- Any deviation from original schedule may be taken care of through mutual consent of both parties as per official need and requirement of the Bank.
- Items will have to be supplied and fixed at PBGB; Head Office within ten (10) days from issuance of Work Order.
- Vendors will have to provide written guarantee of minimum one (1) year against damage of goods/materials.

Applications are to be submitted by addressing to:

CHIEF MANAGER; GAD

Paschim Banga Gramin Bank

Head Office: Natabar Paul Road, Chatterjee Para More, Tikiapara, Howrah – 711101.

Email: ho.gad@pbgb.co.in

**** For any further query, please contact through mail communication or with our contact person Mr. Pawan Kumar Prajapati , officer attached with GAD (Mob: 7003426580) latest by 13/10/2023.**

- Applications are to be submitted in sealed envelope super scribing “Quotation for Furniture and Fixing Work in PBGB” at Bank’s Head Office latest by 18-10-2023 within 3 P.M.
- Tender(s) will be opened at 3.30 P.M. on 18-10-2023.

The Bank reserves the right to reject any / all applications received in response to this notice without assigning any reason thereof.

GENERAL MANAGER



ENCLOSURE- 1

SL NO.	PARTICULARS	QUANTITY	RATE	AMOUNT
1	Supplying and providing wooden cabinet of size 70" x 16" Height-71" made of 19 mm B/B having front pallah of 19 mm B/B, B.W.R grade with 3 shelves inside making 4 compartments. Front & sides are sunmica as per existing design and specification. Back side will be of 6 mm ply B.W.R. grade and polishing complete.	35 Sft.		



ENCLOSURE-I

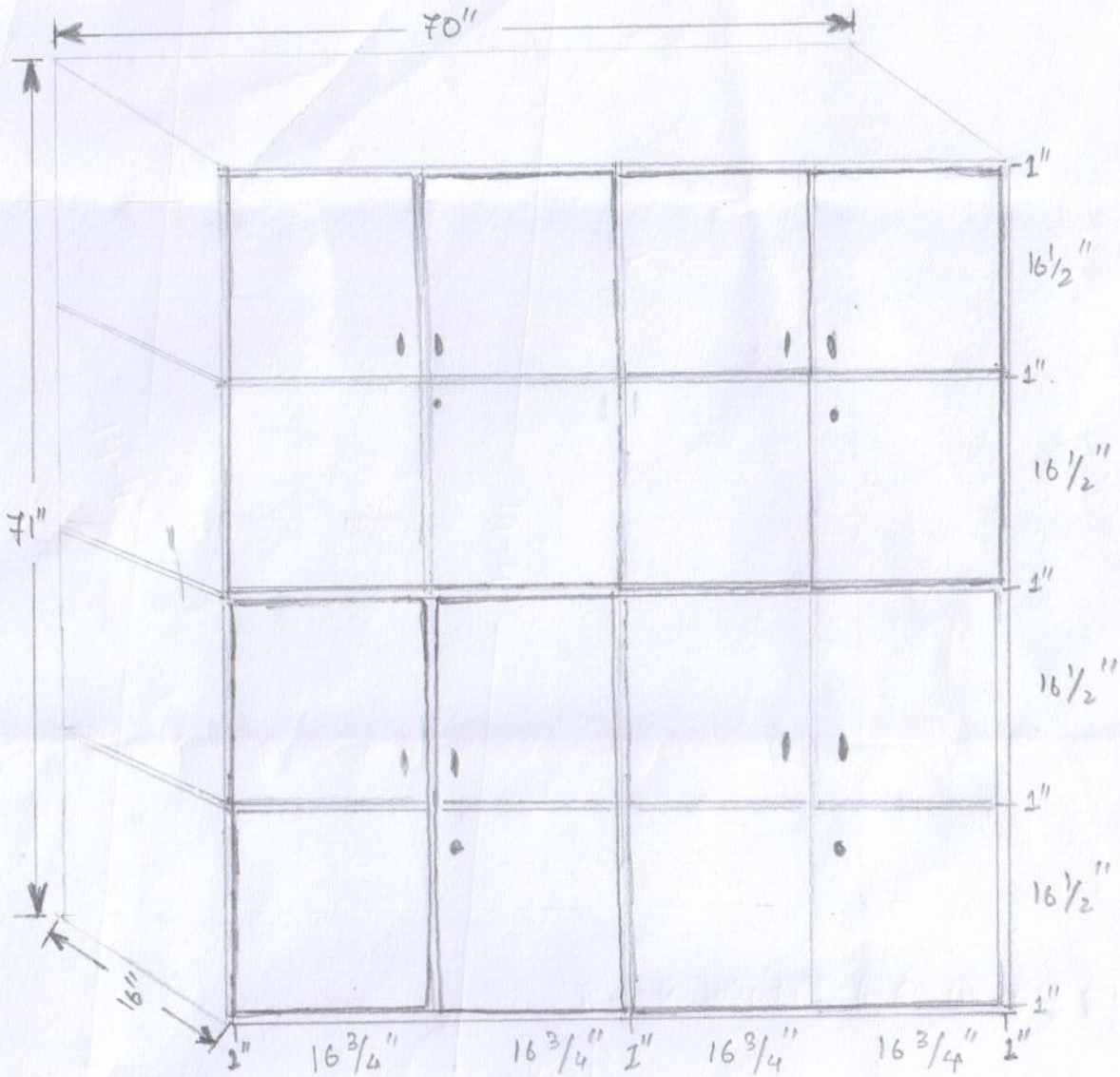

PROPOSED CABINET FOR F.I. DEPARTMENT

Supplying and providing wooden cabinet of size 71" x 70" x 16" made of 19mm B/E or firing. front & side panels are made of 19mm B/E or firing. Inside shelves are made of 19mm B/E or firing. Cabinet is to be finished with lacquer as per existing design and side will be done by 6mm ply B/E or firing. Painting complete.



ENCLOSURE -2

②

SL NO.	PARTICULARS	QUANTITY	RATE	AMOUNT
1	Open Cabinet(wooden) of size 130" x 18" x 18" made of 20 mm B/B ply of BWR grade back 20mm ply, Sides are of 20 mm ply B/B for keeping files with polish complete, Back and inside area will be covered by Sunmica- Sides and Partitions are half round as per the drawing.	1 pc	L.S.	



ENCLOSURE-2

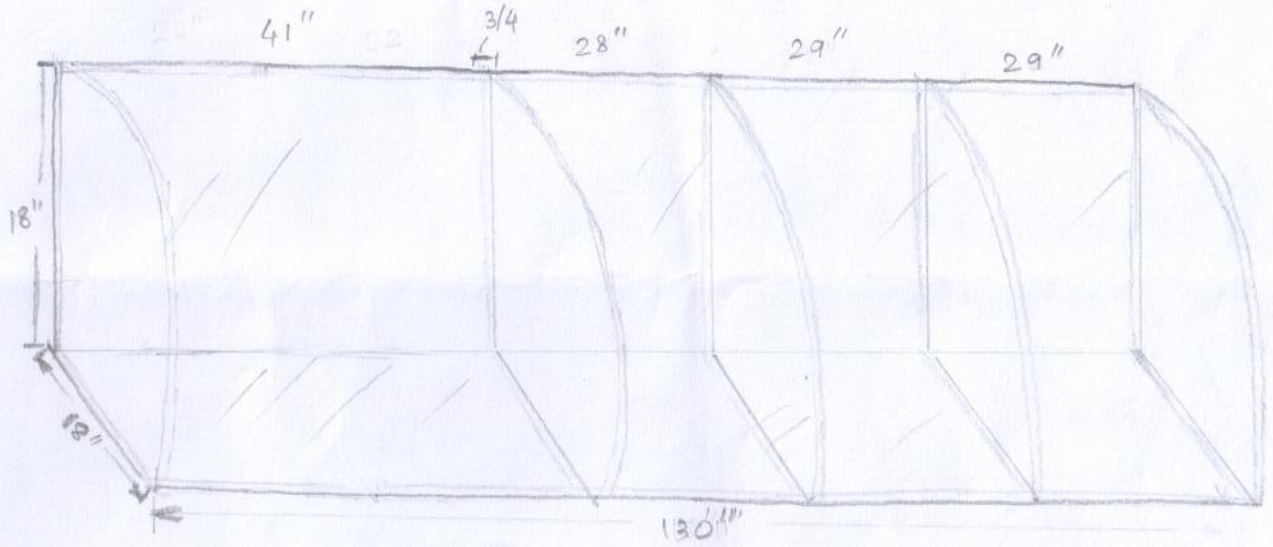

PROPOSED OPEN CABINET FOR CREDIT DEPARTMENT

Size 10' x 10" x 18" made of iron pipe of best grade
 Base down 12" Side 29" x 18" x 12"
 Sides are half round as per drawing



ENCLOSURE-3

3

SL NO.	PARTICULARS	QUANTITY	RATE	AMOUNT
1	Partition wall of size 76" x 96" will be opened for renovation & new frame work will be constructed as per existing design and Specification. With frame work and 6 mm ply with sunmica	51 Sft.		
2	Supplying & providing cabinet (wooden) of Size 60" x 16" Height 96". Having front pallah made of 19 mm Block Board of B.W.R grade & body will be of 19 mm B/B BWR grade having 5 Shelf with 6 compartments. Back will be of 6 mm ply BWR grade. Locks (Godrej) Handles and inside Chitkini(Tower Bolt) etc. Front and Side will be covered by Sunmica as per existing design and Specification	40 Sft		



ENCLOSURE - 3

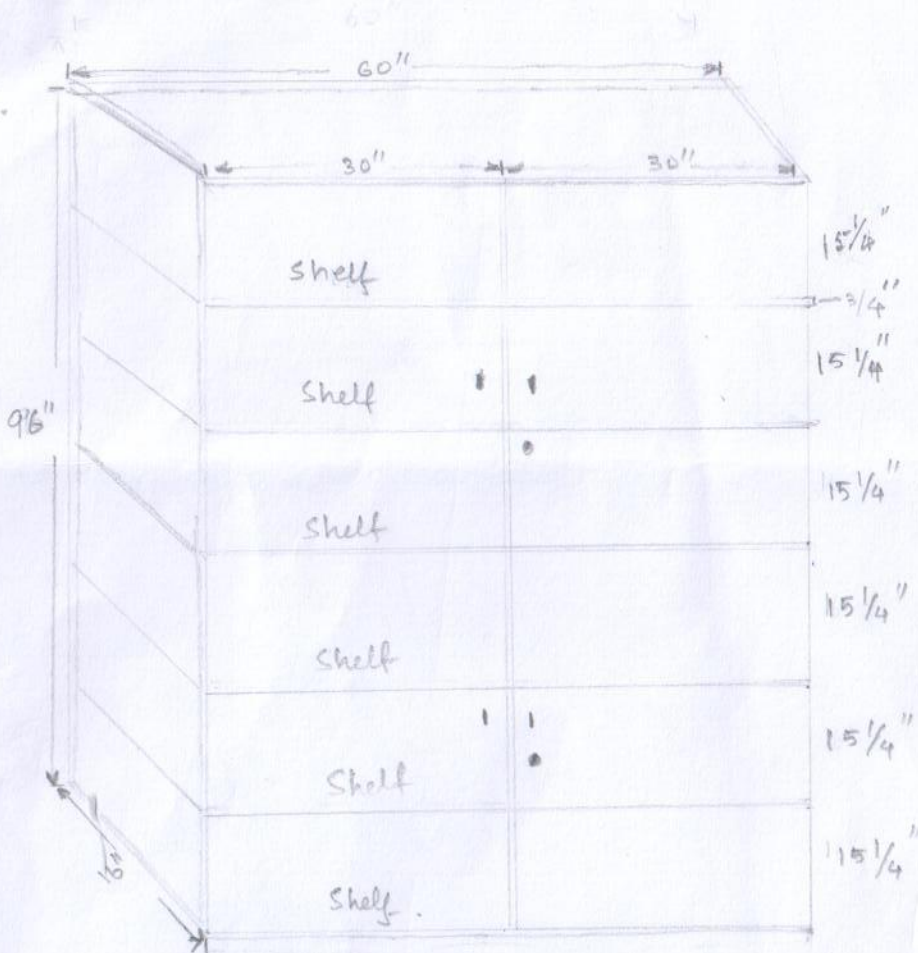

PROPOSED CABINET FOR CREDIT DEPARTMENT

The partition wall dimensions are 60" x 96" which needs to be constructed by using 2" profiled galvanized (welded) steel. The cabinet height is 96". The cabinet is to be made of 1/2" thick steel plate of 16" depth. The back will be of 1/2" BWR grade. The tower will be 16" deep. The cabinet will be constructed as per drawing.



N.B. partition wall will be opened for keeping terminals. Size 6" x 96" & new frame work will be constructed using 2" profiled galvanized steel & specifications etc. as per existing.